

## PADS Professional

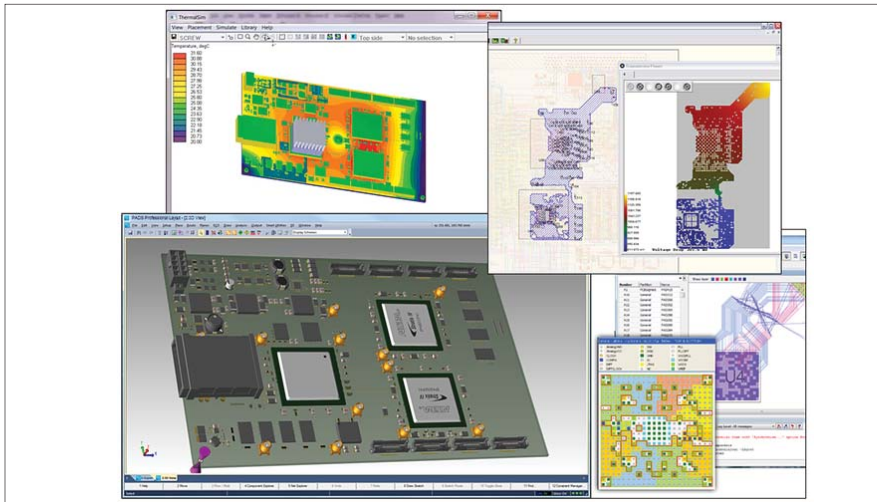

*PADS Professional — a self-contained flow for the engineer who designs complex boards.*

### Overview

Until now, your choice of PCB design tools has been a frustrating compromise. High-end enterprise solutions that handle design complexity come with too much unnecessary overhead and the associated challenges of usability and cost of ownership. Desktop solutions are easier to use and have lower cost, but productivity bogs down as design complexity increases. PADS Professional provides the tools you need for the problems you have to solve:

- Having trouble achieving aggressive PCB design schedule?
- Current tools running out of steam on complex designs?
- Tools keeping up with the newest PCB technology?
- Competitors beating you to market?
- Spending too much time cleaning up your layout before release?

The solution is PADS Professional. It brings you the best of both worlds — based on powerful Mentor Graphics Xpedition technology in combination with a focus on ease of adoption, ease of learning, ease of use, and affordability. PADS Professional directly addresses your challenges and provides the tools and horsepower to solve them.

### FEATURES AND BENEFITS:

- Affordable solution for complex PCB and FPGA systems design
- Self-contained, integrated design flow in one product for hardware engineers or workgroups
- Fewer design spins with virtual prototyping including SI, PI, Thermal, DFM and 3D validation
- Easy to deploy, learn and use by both infrequent and expert users
- Constraint-driven, correct by construction
- Scalable as your needs grow
- Low infrastructure overhead
- Reduced design time through highly integrated capture, constraints, analysis and layout
- Reduced rework and time delays with correct by construction layout
- Quick, efficient design reuse
- Top-down hierarchical approach to placement and planning
- Stunning routing productivity gains with sketch routing
- Native 3D PCB design for placement, routing, MCAD collaboration

## Xpedition Technology Foundation

PADS Professional is built on the same technology foundation as that used to design the world's most complex PCBs. Hardware engineers who do it all — operating independently or in small workgroups — will find PADS Professional to be the perfect solution. Everything needed to design complex PCBs within a tightly integrated flow:

- Hierarchical schematic and table-based design creation with intelligent parts selection and verification
- Logical and physical variant management
- Advanced FPGA synthesis with vendor neutral design environment
- FPGA I/O optimization to reduce signal length, layer count and eliminate costly re-spins
- Unified constraint definitions and management across the flow
- Easy design reuse of schematic, constraints and layout
- Electrical sign off based on full board DRC screening and signal/power integrity analysis
- Board level thermal analysis
- Best-in-class, PCB layout featuring:

A single layout environment

- Concurrent 2D and 3D physical design
- Correct-by-construction approach to placement, plane design and routing
- Hierarchical component planning and placement
- The industry's most powerful interactive routing environment for large busses, single ended and differential pair nets
- Ground-breaking sketch routing
- Advanced fabrication design including HDI, RF, flex circuitry and embedded components

- Component information and library management
- Starter library with over 11,000 part numbers and IPC-7351B compliant Analog/mixed signal SPICE simulation

- PCB documentation and manufacturing outputs
- Design archive management and design review

## Scalability

PADS Professional can grow as the needs of your designs grow. As technology requirements and design complexities continue to expand, additional capabilities and functions can be added to the entire flow that ensure you are able to keep pace with the latest devices, as well as higher speed and advances in technology.

The functionality delivered through advanced products provides capabilities previously unavailable to the individual hardware engineer who does it all and small work groups while remaining affordable and scalable.

Sharing the same Xpedition technology, PADS Professional can easily be upgraded to Xpedition Enterprise, the Mentor Graphics flagship solution for large distributed teams that need extensive library and design data management in a concurrent and collaborative design environment.

## Design Without Compromise

With PADS Professional, your tools won't limit your ability to design. Unlike other systems that advertise "price conscious" tools, the PADS Professional flow is infused with vibrant, dynamic technology for a complete and comprehensive solution.

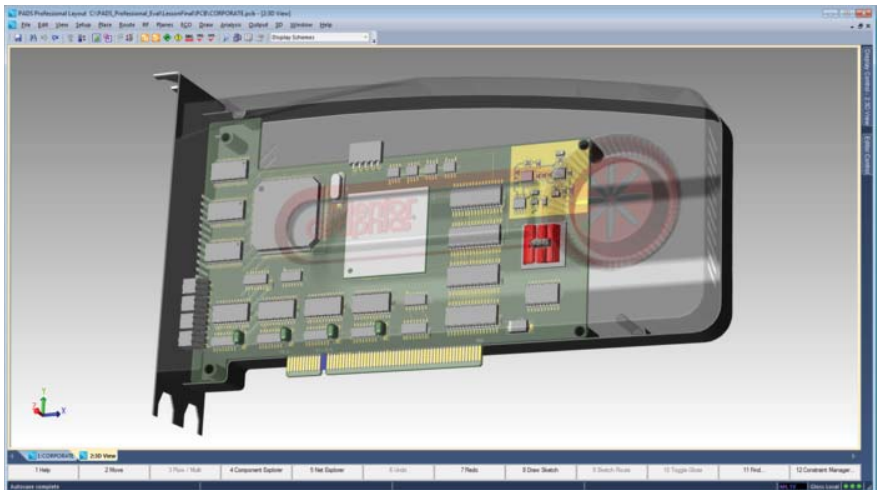

*Integrated native 3D PCB design facilitates visualization, integration and collaboration with MCAD*

## Library and Component Information Management

PADS Professional has an integrated, correct-by-construction component library ensuring that once a part is defined, the symbol, cell and part mappings will be in-sync. This approach eliminates a major cause of design iterations commonly found in netlist-driven design solutions.

What value is the component library if you can't find the parts you need? With PADS Professional it's not a problem because all component information is included in an easy-to-use query and verification system that accepts component information from your choice sources.

Individual engineers and small workgroups often don't have the time or resources to develop a corporate library that adheres to both company and industry standards. PADS Professional delivers an industry-proven starter library that has been developed over several years in a PCB design production environment. This library includes schematic symbols and PCB footprints that will enable you to start designing immediately. There's no need for you to spend valuable time searching for manufacturing datasheets and building your own library from scratch

The starter library contains over 11,000 current manufacturer's part numbers including a wide variety of device types, well-defined partitions for easy navigation, and descriptions of the standards which were used to create the library, which is also IPC-7351B compliant.

## Design Archive Management

Engineers like to try a multitude of "what-ifs" during the design cycle. The problem is keeping track of it all — file naming conventions just don't cut it. PADS Professional includes an intuitive design archive manager allowing engineers to create and restore design archives, view and compare different archives, and create custom reports.

## Design Definition

PADS Professional allows schematic or table-driven design entry of digital, analog/mixed signal, and RF circuits. Unlimited hierarchy lets you organize your design and makes for easy design reuse. If you are using hierarchy, you will need the powerful search and edit capabilities that are hierarchy aware.

Variant management allows you to reuse a single schematic for different variants of your design, and this capability extends into layout as well.

Project and design navigation is intuitive while the built-in component information browser allows you to easily research and instantiate parts on your schematic. Extensive rules checking eliminates errors prior to layout, increasing the quality of your design. Tight integration, including cross probing, keeps your schematic, constraints and layout in sync at all times allowing you to manage and track changes as your design progresses.

## FPGA Synthesis

Now that FPGAs have become as complex, in many uses, as ASICs and SoCs, advanced FPGA implementation flows must be adopted by hardware engineers. Synthesis is a critical component of an integrated, FPGA vendor neutral design environment. By delivering high quality results and

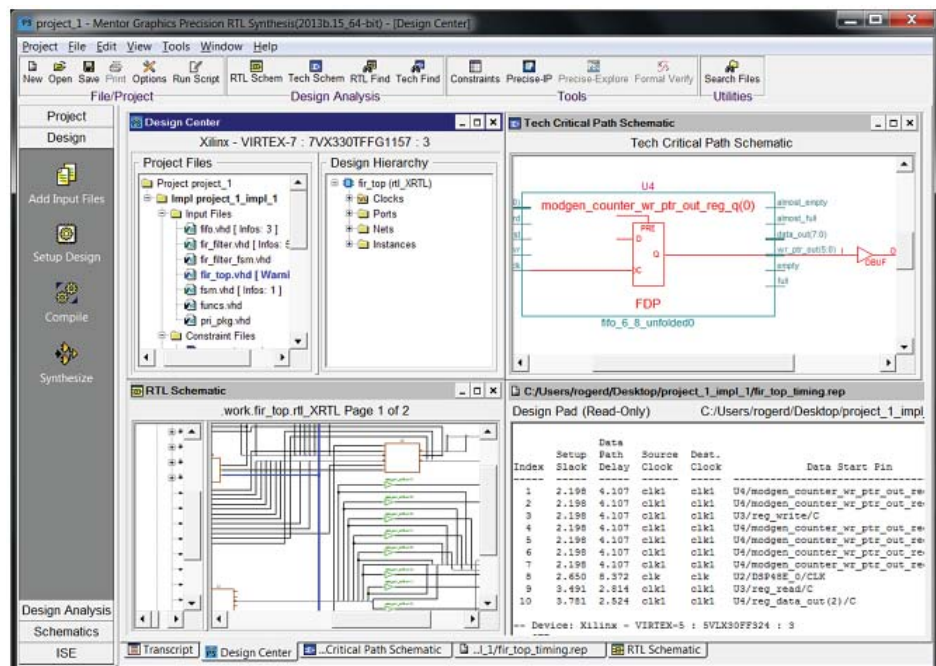

FPGA synthesis is much simplified using the PADS Professional FPGA implementation flow.



offering industry-specific requirements, PADS Professional offers breakthrough advantages for FPGA applications. The implementation flow supports applications ranging from commercial datacom and telecom designs through automotive to military-aerospace and safety-critical systems that require not only performance but also specific system requirements such as power efficiency.

Because more FPGAs are being designed into low-power applications, you not only need to carefully select the most power efficient device but also must ensure their implementation flows reduce device utilization and power to the greatest extent possible. Starting with design entry and compilation, PADS Professional offers leading edge HDL language coverage for proficient interpretation and optimization from HDL to the target FPGA architecture resulting in smaller and faster designs. Likewise, architecture specific optimization for each FPGA device fully utilizes architecture specific features and advantages to meet design requirements.

## FPGA I/O Optimization

Today's FPGAs are very powerful devices with high pin count, numerous I/O standards and high speed capabilities. In addition, advanced implemented logic in the FPGA very often requires that hundreds of logical signals be mapped to physical signals. This is a challenge for hardware engineers to match the HDL world with the electrical world.

An automated FPGA symbol generation process typically saves as much as 30X over traditional manual processes. The process uses correct-by-construction, rule-driven I/O assignment with a library of FPGA vendor devices, including early access to not yet released devices.

In light of these challenges, PADS Professional fully supports FPGA-on-board integration, reducing time to market and manufacturing costs through reduced layer counts, via counts and design cycle time.

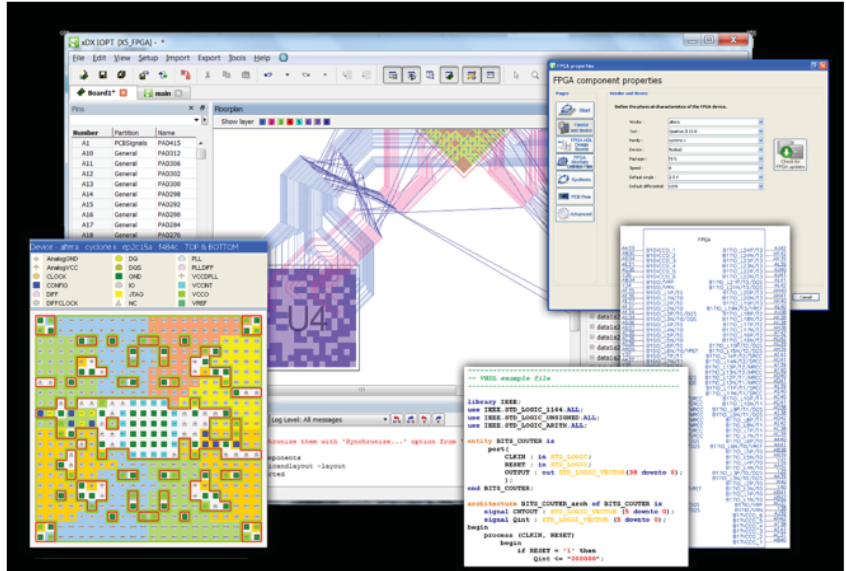

*PADS Professional bridges HDL-based FPGA design and PCB design for automated, fast and error-free, bi-directional information exchange.*

## Achieving Electrical Sign-off

PADS Professional includes a powerful and fast design rule checking tool. It verifies complex design rules that are not easily simulated, such as rules for EMI/EMC. With support for design rule checks for items such as traces crossing splits, reference plane changes, shielding, and via checks, you can quickly and easily pinpoint trouble spots on your board that can cause issues with EMI/EMC, signal integrity, and power integrity.

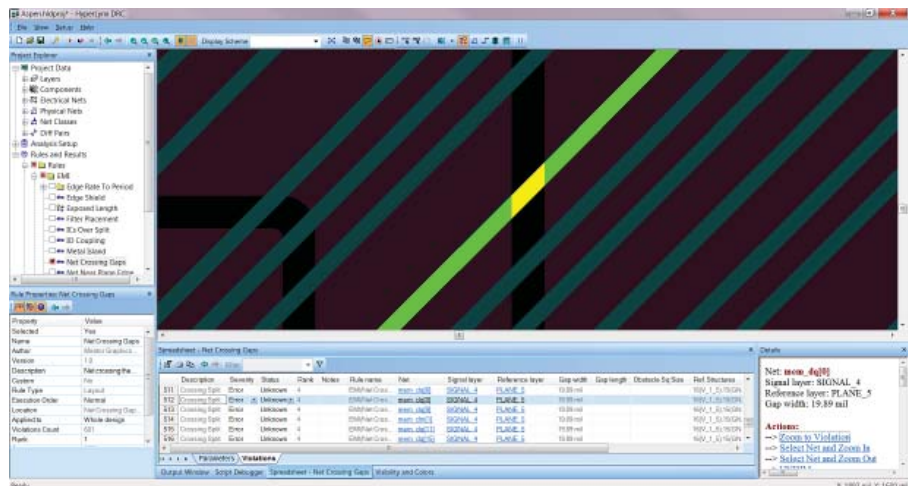

*Design rule checks can be performed on boards for EMI/EMC issues, as well as signal integrity and power integrity issues. It is highly customizable, allowing users to create DRCs for any check they might otherwise perform manually.*

The combination of design rule checking for full-board screening, coupled with advanced signal/power integrity analysis, provides you with a fast, accurate solution for achieving electrical sign-off.

## Constraint Management

As PCBs increase in complexity and density, a higher percentage of the design must be implemented with strict adherence to design rules. Manual documentation, translation, and interpretation of design rules often cause longer product development cycles and increased costs. The constraint manager provides a fully integrated, constraint-driven design methodology that reduces design costs and time-to-market by automating design rules communication and eliminating unnecessary PCB prototypes and re-spins. The constraint manager provides the engineer with direct control over the PCB layout.

The constraint manager supports bi-directional cross probing, highlighting and selecting between a spreadsheet-based constraint interface, schematic capture and PCB layout. Any net can be analyzed for signal integrity pre-layout when developing a topology template, which can then be used in the constraint manager.

As the number and complexity of constraints explodes, the constraint manager comes with a lightweight, easy to learn, context-sensitive tool for editing constraints within the schematic or PCB layout.

## Analog Simulation

PADS Professional includes a board-level analog/mixed signal simulation environment integrated with the schematic editor. Using a common schematic to drive both the simulation and PCB design eliminates costly and error-prone schematic re-entry, significantly shortening the overall development cycle.

## Thermal Analysis

PADS Professional incorporates thermal analysis to allow engineers to analyze board-level thermal problems on placed, partially routed, or fully routed PCB designs. Temperature profiles, gradients, and excess temperature maps enable engineers to resolve board and component overheating early in the design process.

## Signal Integrity Analysis

PADS Professional offers powerful and easy-to-use signal integrity capabilities, including DDRx validation. With pre-layout analysis capabilities for defining stackup and routing constraints, to verification of the routed board to ensure your design goals are met, PADS Professional offers a rich environment for your signal integrity analysis needs based on renowned HyperLynx technology.

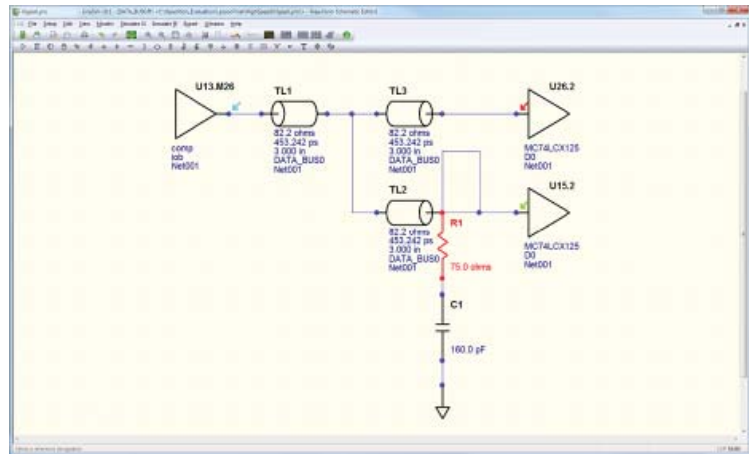

*The analysis environment is tightly integrated with schematic and layout, simplifying signal integrity analysis.*

## Power Integrity Analysis

The power integrity analysis environment is easy to set up and use, getting simulation results without requiring weeks of software training. You can identify power distribution problems early in the design, even prior to layout. You can also identify IR drop problems with your design that would be difficult to identify in the lab, and

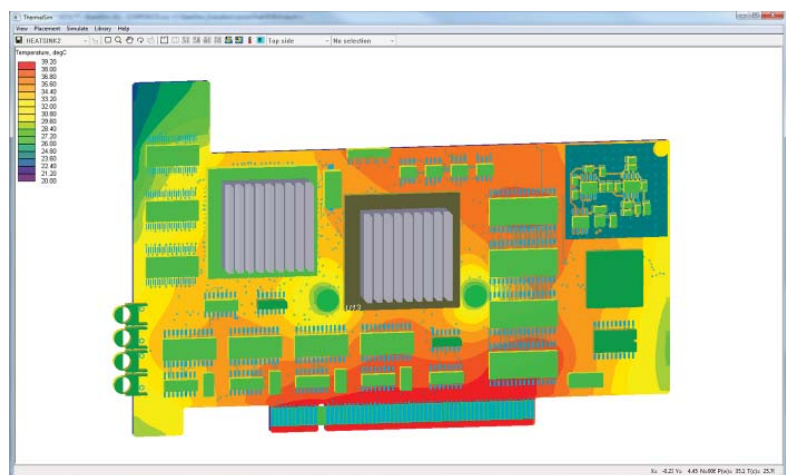

*Integrated thermal analysis allows engineers to detect potential heat problems without expensive prototyping.*

investigate solutions in an easy-to-use “what-if” environment. Once the layout is complete, you can validate the results to ensure that appropriate guidelines were followed. This will ultimately help you reduce prototype spins and get to market faster, while creating more reliable products.

## PCB Layout

At the heart of PADS Professional is the industry’s most powerful PCB layout technology, all within a single editing environment. Xpedition technology is used to design the world’s most complex boards that include complex, constrained topologies and power distribution, differential pairs, wide busses, HDI, flex and large, fine pitch BGAs.

PADS Professional supports a correct-by-construction approach that produces high quality results and reduces costly iterative clean-up of constraint violations. Dynamic glossing of traces reduces segments, prevents acute angles and obeys pad entry rules. Dynamic high performance healing of planes and thermal reliefs allows

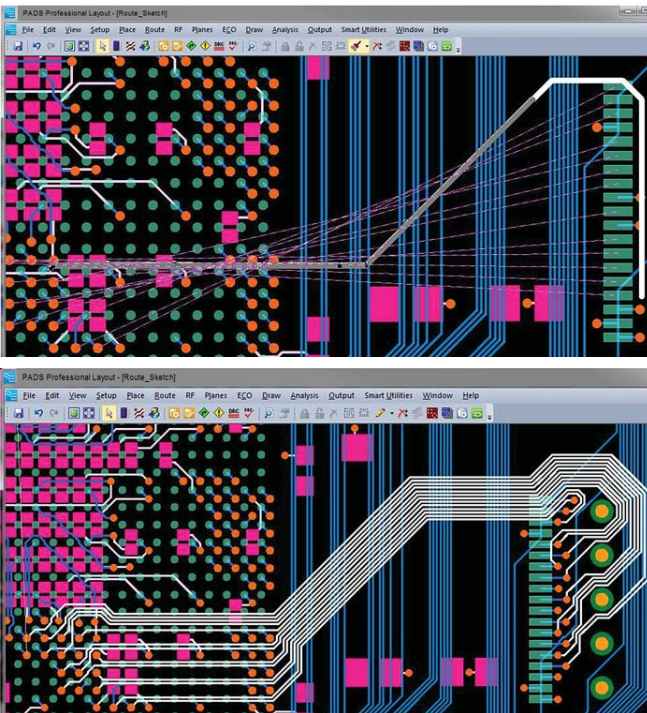

*New routing technology allows the designer to sketch the path of signals, then the interactive router efficiently routes those traces. In the top image, the designer has “sketched” the path desired for the signals shown in purple. In the bottom illustration, the Sketch Router has efficiently routed the traces according to the designer’s sketch.*

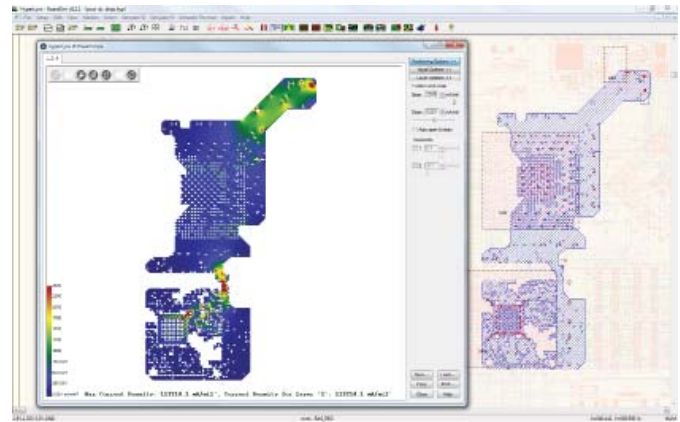

*Tight integration makes power integrity analysis easier to use.*

real time creation of complex power distribution topologies. Fully integrated, true parametric, 3D layout with placement, constraints, DRC checking, and photo realistic visualization minimizes MCAD iterations.

PADS Professional includes revolutionary placement and interactive routing technology focused on productivity. Hierarchical group placement allows you to place your board taking advantage of natural or defined component groupings in your design. PADS Professional combines automatic and interactive technology keeping you in control while automating the more mundane tasks. You’ll be amazed at the sheer power of the glossing, push and shove during trace manipulation.

## Sketch Router

In addition, the ground-breaking sketch routing in PADS Professional takes productivity to a whole new level. Taking your design intent and routing strategies in the form of a super-efficient sketch, the system automatically fans out, untangles, and routes the associated nets with the quality of an experienced PCB designer. Sketch routing reduces complex routing times by orders of magnitude.

Starting with the Sketch Router, a designer can draw a sketch path to dictate the location for the routing of the selected netlines. The Sketch Router will route individual, dozens, or even hundreds of netlines many times faster than manual routing. Sketch routing focuses on quality; little cleanup is needed, often none at all. The high routing completion rate (typically >90%) is due to its ability to automatically optimize the escapes from components like BGAs so they are optimal for routing without any additional vias.



## 3D Layout

One of the challenges to integrating your PCB design process into the electromechanical world is the ability to “left-shift” validation into the PCB layout processes to find electromechanical design problems early, eliminating costly re-design late in the cycle. 3D layout is a fully integrated 2D/3D environment using the same selection, planning and placement functionality as PCB layout.

The true parametric 3D mechanical kernel uses a complete set of 3D constraints with dynamic collision detection and batch verification to ensure your electromechanical designs are error free. Full photo-realistic visualization of board elements, like traces, components, silk screen, solder mask, and vias, is provided with transparency, z-axis scaling, view/ rotation control, and x/y/z cut planes.

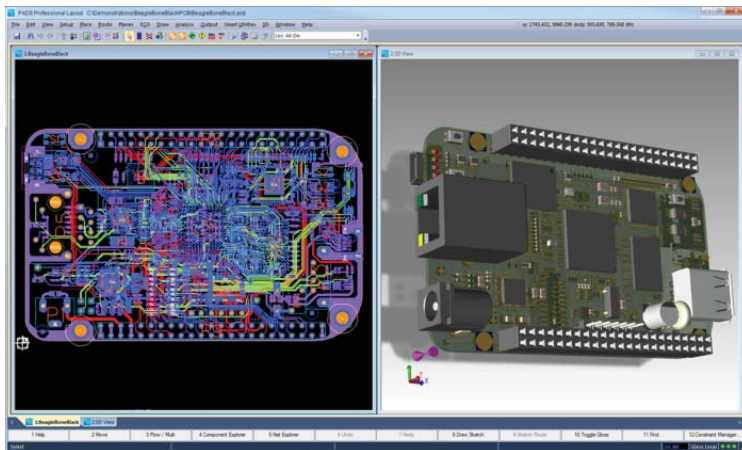

*3D visualization, placement and validation optimizes PCB electromechanical design.*

Included with 3D layout is a ~4.5 million-part 3D model library. The ability to import your own models from STEP files is also available. Models are easily mapped and aligned with included library tools. You can also import

mechanical components like chassis and heat sinks, and even sub-assemblies of other PCB designs, providing true mechanical multi-board capability.

Once your design is complete, you can use the integrated MCAD Collaboration tool to pass information to popular industry mechanical design systems. You can also export your design in standard industry formats, and utilize the 3D PDF and documentation tools to complete your design package.

## PCB Manufacturing

Manufacturing documentation and outputs can be directly created within the layout environment, so any last minute layout changes are automatically synchronized. Automated and customizable creation and distribution of manufacturing data results in increased quality, accuracy and design throughput. PADS Professional is also tightly integrated with Valor NPI for concurrent DFM validation and optimized hand-off to manufacturing, using the ODB++ format to ensure that all manufacturing data is included and synchronized, and that design intent is maintained. Additional CAM formats and reporting, including Gerber, NC drill, and pick and place, are also supported.

## No Compromise

PADS Professional directly addresses your technological challenges and provides the tools and horsepower to solve them. Achieve those aggressive design schedules and stay ahead of the competition, confident in the knowledge that you have the right tools to address those complex challenges not just today, but tomorrow as well.

PADS Professional: the best of both worlds — powerful Mentor Graphics Xpedition technology combined with a focus on ease of adoption, ease of learning, ease of use, and affordability.

**For the latest product information, call us or visit: [www.pads.com](http://www.pads.com)**

©2015 Mentor Graphics Corporation, all rights reserved. This document contains information that is proprietary to Mentor Graphics Corporation and may be duplicated in whole or in part by the original recipient for internal business purposes only, provided that this entire notice appears in all copies. In accepting this document, the recipient agrees to make every reasonable effort to prevent unauthorized use of this information. All trademarks mentioned in this document are the trademarks of their respective owners.

### Corporate Headquarters

**Mentor Graphics Corporation**  
8005 SW Boeckman Road  
Wilsonville, OR 97070-7777  
Phone: 503.685.7000  
Fax: 503.685.1204

### Sales and Product Information

Phone: 800.547.3000  
[sales\\_info@mentor.com](mailto:sales_info@mentor.com)

### Silicon Valley

**Mentor Graphics Corporation**  
46871 Bayside Parkway  
Fremont, CA 94538 USA  
Phone: 510.354.7400  
Fax: 510.354.7467

### North American Support Center

Phone: 800.547.4303

### Europe

**Mentor Graphics  
Deutschland GmbH**  
Arnulfstrasse 201  
80634 Munich  
Germany  
Phone: +49.89.57096.0  
Fax: +49.89.57096.400

### Pacific Rim

**Mentor Graphics (Taiwan)**  
Room 1001, 10F  
International Trade Building  
No. 333, Section 1, Keelung Road  
Taipei, Taiwan, ROC  
Phone: 886.2.87252000  
Fax: 886.2.27576027

### Japan

**Mentor Graphics Japan Co., Ltd.**  
Gotenyama Garden  
7-35, Kita-Shinagawa 4-chome  
Shinagawa-Ku, Tokyo 140-0001  
Japan  
Phone: +81.3.5488.3033  
Fax: +81.3.5488.3004



MF 3-15 1031050-W